

First, safety usage guideline:

This product was designed, with full consideration of the person and the safety standards association. But improper usage will cause harm to the user. In order to guarantee the user, safety and benefit, please read the instructions below carefully before use:

1. Do not use this product in heavy rain or moisture, in order to prevent fire hazard or electric shock danger, the product must be completely dry?
2. Do not attempt to replace original parts with alternate parts,
3. Do not keep in moist, dusty, high temperatures; do not use in moist environments, suggested to be used in conditions of -20°C to $+50^{\circ}\text{C}$.
- 4 Do not keep in flammable, explosive, corrosive, flammable solid, flammable Gas, flammable Liquid uses?
- 5 Do keep away from children and other underage persons.
6. Do charge inverter and the accumulator cell, polarity cannot be reversed and must be in connected with each corresponding polarities such as negative with negative, positive with positive.
7. If product exceeds the maximum potential may causes system to overload, there is a fuse protector in which the current will be shut off and meanwhile. The same occurrence will happen if there are too many appliances used: television, radio, and other electrical portable appliances. in this condition the main switch on the product should be shut off and after all and any switches have been turned off from the appliances, then restart the convertor, and appliances may be used again. Each individual appliance should be operated singularly, the inverter should be used with the appliance which requires the most power first and so forth meaning from greatest power usage to least.
8. Do not put any liquids or objects into the system.
9. Before uses please confirm whether the AC input voltage does confirm to the requirement, and check the input output connections are properly connected, poor connection may result in poor results in usage and low voltage or power.
10. This product cannot be improperly connected, otherwise can damage this product.

11. Do not use a damp or wet rag to clean the product, do not use any aerosole cans or cleaning agents on this product, only clean product with a dry rag.

12. If you are not a technician, please do not remove covering, in order to avoid an electric shock!

2nd, product function synopsis:

1. This product can convert a 12v/24v direct current into a 110v/220v alternating current, and can be used as a battery charger.

2. The function of this product can transfer electricity to the appliances and continue to charge while in use of current transfer. The product can result as alternating current output and UPS switch function as well. Meanwhile, it also uses PWM(Pulse-Width Modulation) Mode, which has several advantages: small volume, light in weight, noise is quiet, no contamination automatic safety protection and automatic switch function and so on.

3 It is suitable in travels on each kind of vehicles as well as outside, the camping, rowing a boat or for notebook computer travel usage. Digital camera, electric appliance equipment and so on ; Moreover also may widely apply in the use for a fan, solar energy- electricity generation area as well as other power supply unstable area; Can be the domestic electric appliances (for example: The television, the computer, DVD, VCD, the satellite receiver, the printer, the fluorescent lamp, the chiller, the sound, the ventilator, the electric drill, the drilling machine, the illumination, the motor, the microwave oven, the electronic mechanical games and so on) provide the stable power source.

■ 600W, 800W, 1000W with UPS function is shown on the following inverter diagram:

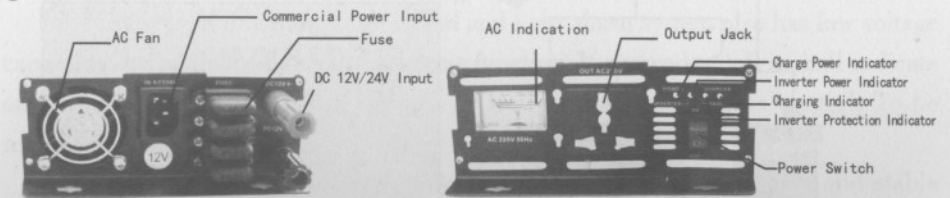

600W, 800W, 1000W Input profile

600W, 800W, 1000W Output profile

■ 1500W, 2000W, 3000W, 5000W with UPS function inverter chart

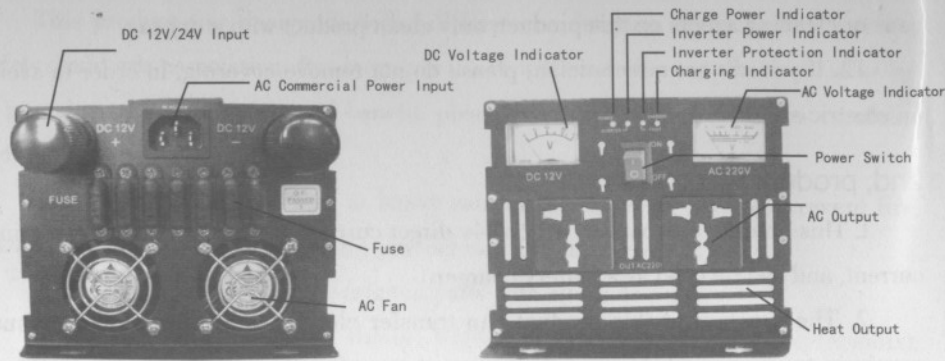

1500W, 2000W, 3000W, 5000W Input profile

1500W, 2000W, 3000W, 5000W Output profile

Chart for the interactive connect of inverter with the UPS function and the storage battery and the commercial power.

■ INSTALLATION SCHEMATIC

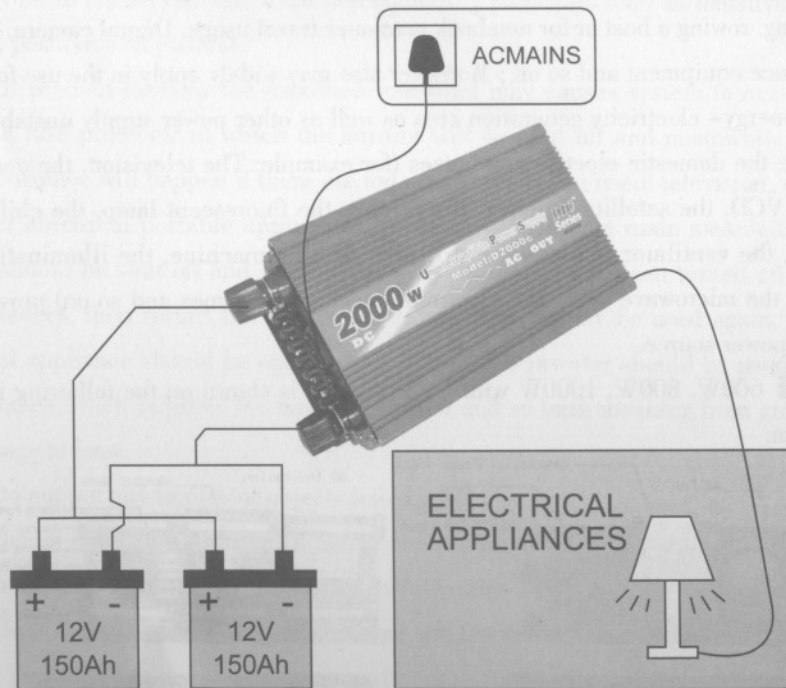

3rd, the product operation explains that,

1 Connection of battery and inverter: Accumulator cell contains two wires one red and one black. When connecting the wires be sure to connect the red wire with the positive terminal of the battery and connect the black wire with the negative terminal of the battery. Check to be ensuring that the connections are securely connected.

2 Connection of load and inverter: before connecting this product please be sure that the product is set to the off position. Make sure the inverter and the battery is properly connected, then connect the load to the inverter by means of plug to plug output socket.(ac) and then turn on the inverter switch now the product indicator light which is green should be on. The volt meters needle indicator should be pointing to the numeric scales of 110v/220v green section of the ac category. So it indicating that the inverter is functioning. Now turn on the load power switch.

3. This product and commercial power connections ---be sure the above instructions are followed properly and proceed to charge the inverter with commercial power following by a red indicator light indicating the inverter is being charged. And the needle indicator will also indicate the position of 110v/220v in the green section of the volt meter. Please refer to diagram 3.

4th, the product main characteristic:

1. It uses the import primary device manufacture, advanced circuit design, not only enhanced the complete machine work reliability greatly, reduced the electromagnetic interference, moreover increased the complete machine output precision greatly.

2. It has the starting soft start function, even if belt heavy load, also cannot damage this product and the load, strengthened the belt to carry the function.

3. It has the overload ability to continue to function properly, low pressure over heating protection, the overload, the short circuit protection, in case of misconnection or improper connection protection. it automatically protects the system.

4. It has the ability to indicate sound and light alarm system also has low voltage capability to function. Battery' s charging function. If charged to full it shall indicate on the indicator. Temperature control, as well as temperature loss control. To be regulated by fan control.

5. It has high and low voltage protection in order to provide a safe and stable environment for your appliances or electrical products.

6. This device consists of 3 sections, first section contains: uses the very

consistent and constant current rapid charge rate, by using backup reserve ' s from the u.p.s to charge the inverter.

Section 2 transfers the constant voltage gradually to the battery until full of electricity, for the battery absorbing energy duration, in order to protect the battery electrode long term life. To maintain battery consistency and efficiency.

Section 3: when the inverter has verified the battery is full, when in use the voltage reading will remain the same voltage without loss. The average battery voltage is 13.8v; it will automatically detect how much voltage is remaining in the battery. Once it finishes charging the battery it will automatically stop charging. It is power efficient.

7. The inverter has the long term usage for your computer, the ups has the automatic switch function. It makes your life easier.

8. It has the AC output voltage indication function; one glance and it will be simple to understand.

9. The volume is small, the weight is light, does not have the noise, does not have pollution, moreover the contour elegant appearance,

10. This product can be used as an emergency power source, for everyday use, this product will ultimately become the ideal power source.

5th: Protection function summary:

1. Low voltage warning --- when the dc voltage is at 9.5v -11v the alarm will sound intermittently. And the red led light will be on. in this state the storage battery is low. And it requires recharging.

3. High voltage protections ---When the DC input voltage is higher than 15V/30V, the alarm will sound intermittently. Simultaneously the red LED lamp glistens, at this point the product will automatically turnoff the output and protect this inverter.

4. Misconnection protection: ---When this product and the accumulator cell polarity meets incorrectly-, can burn out the DC input fuse immediately, this will occur immediately after the accumulator cell ties, the replacement same specification fuse when replacing the fuse you must disconnect the wire from the battery terminal. And you must remember to replace with the same fuse specifications.(there is one fuse provided within the package). Then you can reconnect the inverter properly to the battery with the positive to positive and negative to negative connection specs.

5. over-load protections ---When the load exceeds the power rating, 3 to 5

seconds -- simultaneously the green LED lamp quickly flashes, this product will automatically turnoff the output and protect this product.

6. Short circuit protections ---When the load surpasses the power rating 2 times or the output short-circuit, after the first two seconds the alarm has been able to send out beeps, the green LED lamp flashes quickly, also this product can the automatic turnoff output protect this product.

7. Temperature protection control ---when the inverter is functioning or in use, the outer covering surface temperature surpasses 60 degrees--70degrees, the alarm has been able to send out beeps, the green LED lamp flashes quickly, also this product can the automatic turnoff output protect this product.

8. AC input low voltage protection ---When the commercial power (AC input voltage) is lower than 150, this product can automatically turn off the commercial power output, simultaneously stop the battery charging, the green charging light will shut off, it will also automatically cut off the output connection. There after shall provide you with a very stable connection to the load.

9. AC input high pressure protection ---When the commercial AC input voltage is higher than 250V, this product can automatically turn off commercial power output, and simultaneously stop the battery charging process, the green charging light will shut off, it will also automatically cut off the output connection. There after shall provide you with a very stable connection to the load.

Attention: if the inverter shall fall into the state of low voltage protection, the high voltage protection, the over-load protection, the short circuit protection, the over heatprotection, this product needs to restart in order to do normal work, by doing this you shall protect your load and this product.

6th, inverter choice:

1. Common electronic products have all sectioned out the rated power which it uses, its rated power should be smaller than this product rated power.

2. Power estimate method: The load power (W) sum total is equal to this product rated power (w).

If you need at the same time, simultaneously to use two computers (250W?), lightens a light bulb (60W), turns on a television (200W) and a ventilator (180w), then their total output for $250W+60W+200W+180W=940W$, then you need a rated power of 1000W from the inverter, determined by this analogy. you need to choose which type of inverter is required using this example.

7th, rechargeable battery choice:

1. You need to use the correct voltage to match the appliance with the rechargeable battery, also can provide enough operating current for this product (i.e. not to be smaller than this product battery rating, full load concurrent input current), for example: You have a 12V-220V-2000W inverter, you should select a bigger than 200AH the rechargeable battery.(Formula as follows):

*Rated power W (a volt-ampere = watt) / you need the input voltage V *1.2 = how many amperes (A or A) (for example 12V)*

2. Accumulator cell period of revolution length may calculate according to the below formula that,

*Capacity of storage battery AH (ampere hour) / (load total output/this product DC input voltage)*80% = period of revolution (hour)*

Attention: Rechargeable battery of revolution length also with its quality and new old related and so on.

8th, product main technical parameter: (Form1 and Form2 “√” are the main technical parameter of the inverter)

1. Inversion part

Power Rating		600W		800W		1000W	
Continue Output Rating		600W		800W		1000W	
Peak Power Rating Output		1200W		1600W		2000W	
Input Section	DC Input Voltage	12V	24V	12V	24V	12V	24V
	DC Operating Voltage	11-15V	21-29V	11-15V	21-29V	11-15V	21-29V
	DC Low-voltage Protection	9V-10.5V	18.5-20.5V	9V-10.5V	18.5-20.5V	9V-10.5V	18.5-20.5V
	DC Low voltage Alarm	9.5V-11V	19.5-21V	9.5V-11V	19.5-21V	9.5V-11V	19.5-21V
	DC Over voltage protection	≥ 15V	≥ 29V	≥ 15V	≥ 29V	≥ 15V	≥ 29V
	Fuse	40A × 2	20A × 2	35A × 3	20A × 2	40A × 3	20A × 3
	Quiescent Current	≤ 0.6A	≤ 0.6A	≤ 0.8A	≤ 0.8A	≤ 1A	≤ 1A
	Input Parameter of the Product						
Output Section	Output waveform	Modified Sine Wave		Modified Sine Wave		Modified Sine Wave	
	Output Voltage	110 ± 5%	220 ± 5%	110 ± 5%	220 ± 5%	110 ± 5%	220 ± 5%
	Output Frequency	60HZ ± 1%	50HZ ± 1%	60HZ ± 1%	50HZ ± 1%	60HZ ± 1%	50HZ ± 1%
	Input Parameter of the Product						

Transfer Efficiency	≥ 90%	≥ 90%	≥ 90%
Overload Protection	600W--720W	800W--960W	1000W--1200W
Short-circuit Protection	Yes	Yes	Yes
Operating Temperature	-10° C--+50° C	-10° C--+50° C	-10° C--+50° C
Temperature Protection	+60° C--+70° C	+60° C--+70° C	+60° C--+70° C
Green LED Indicator	Green Light(Working),Flash(Overload protection)		
Red LED Indicator	Red Light(Error Protection)		

2. Contra-variant part

Power Rating		1500W		2000W		3000W		5000W	
Continue Output Rating		1500W		2000W		3000W		5000W	
Peak Power Rating Output		3000W		4000W		6000W		10000W	
Input Section	DC Input Voltage	12V	24V	12V	24V	12V	24V	12V	24V
	DC Operating Voltage	11-15V	21-29V	11-15V	21-29V	11-15V	21-29V	11-15V	21-29V
	DC Low-voltage Protection	9V-10.5V	18.5-20.5V	9V-10.5V	18.5-20.5V	9V-10.5V	18.5-20.5V	9V-10.5V	18.5-20.5V
	DC Low voltage Alarm	9.5V-11V	19.5-21V	9.5V-11V	19.5-21V	9.5V-11V	19.5-21V	9.5V-11V	19.5-21V
	DC Over voltage protection	≥ 15V	≥ 29V	≥ 15V	≥ 29V	≥ 15V	≥ 29V	≥ 15V	≥ 29V
	Fuse	40A × 2	20A × 2	35A × 3	20A × 2	40A × 3	20A × 3	40A × 3	20A × 3
	Quiescent Current	≤ 1.6A	≤ 1.6A	≤ 1.6A	≤ 1.6A	≤ 1.6A	≤ 1.6A	≤ 1.6A	≤ 1.6A
	Input Parameter of the Product								
Output Section	Output waveform	Modified Sine Wave		Modified Sine Wave		Modified Sine Wave		Modified Sine Wave	
	Output Voltage	110 ± 5%	220 ± 5%	110 ± 5%	220 ± 5%	110 ± 5%	220 ± 5%	110 ± 5%	220 ± 5%
	Output Frequency	60HZ ± 1%	50HZ ± 1%	60HZ ± 1%	50HZ ± 1%	60HZ ± 1%	50HZ ± 1%	60HZ ± 1%	50HZ ± 1%
	Input Parameter of the Product								
Transfer Efficiency		≥ 90%		≥ 90%		≥ 90%		≥ 90%	
Overload Protection		600W--720W		800W--960W		1000W--1200W		1000W--1200W	
Short-circuit Protection		Y		Y		Y		Y	
Operating Temperature		-10°C--+50°C		-10°C--+50°C		-10°C--+50°C		-10°C--+50°C	
Temperature Protection		+60°C--+70°C		+6°C--+70°C		+60°C--+70°C		+60°C--+70°C	
Green LED Indicator		Green Light(Working),Flash(Overload protection)							
Red LED Indicator		Red Light(Error Protection)							

1. Charge Battery Section

Power Rating		600W		800W		1000W	
Input Section	AC Input Voltage	110V	220V	110V	220V	110V	220V
	AC Operating Voltage	50HZ/60HZ	50HZ/60HZ	50HZ/60HZ	50HZ/60HZ	50HZ/60HZ	50HZ/60HZ
	AC Operating Voltage	85V-130V	170V-250V	85V-130V	170V-250V	85V-130V	170V-250V
	AC Low voltage Protection	≤ 75V	≤ 150V	≤ 75V	≤ 150V	≤ 75V	≤ 150V
	AC over-voltage Protection	≥ 130V	≥ 250V	≥ 130V	≥ 250V	≥ 130V	≥ 250V
	AC Input Insurance	10A	5A	10A	5A	10A	5A
	Input Parameter of the Product						
Charging Method	Intelligent positive-negative pulsed charge		Intelligent positive-negative pulsed charge		Intelligent positive-negative pulsed charge		
Output Section	Charging Process	Precharge\Charge\Floating Charge\Full		Precharge\Charge\Floating Charge\Full		Precharge\Charge\Floating Charge\Full	
	Charging Current	Max10A		Max10A		Max10A	
	Charging Voltage	14.5V-16V	29V-32V	14.5V-16V	29V-32V	14.5V-16V	29V-32V
	Input Parameter of the Product						
Inverter switch commercial power time	≤ 10ms(Your PC needn' t restart in use of this product)						
Commercial power switch inversion time	≤ 10ms(Your PC needn' t restart in use of this product)						
Required for Inverter switch commercial power	Must matches AC normal operating voltage						
Required for Commercial power switch inversion	No commercial power、AC low voltage protection、AC high voltage protection						
Green LED Operating Indication	Green Light(Operating)						
Red LED Operating Indication	Red Light(Charging)						

2. Contra-variant part

Power Rating		1500W		2000W		3000W		5000W	
Input Section	AC Input Voltage	110V	220V	110V	220V	110V	220V	110V	220V
	AC Operating Voltage	50HZ/60HZ	50HZ/60HZ	50HZ/60HZ	50HZ/60HZ	50HZ/60HZ	50HZ/60HZ	50HZ/60HZ	50HZ/60HZ
	AC Operating Voltage	85V-130V	170V-250V	85V-130V	170V-250V	85V-130V	170V-250V	85V-130V	170V-250V
	AC Low voltage Protection	≤ 75V	≤ 150V	≤ 75V	≤ 150V	≤ 75V	≤ 150V	≤ 75V	≤ 150V
	AC over-voltage Protection	≥ 130V	≥ 250V	≥ 130V	≥ 250V	≥ 130V	≥ 250V	≥ 130V	≥ 250V
	AC Input Insurance	15A	7.5A	20A	10A	30A	15A	50A	25A
	Input Parameter of the Product								

Output Section	Charging Method	Intelligent positive-negative pulsed charge		Intelligent positive-negative pulsed charge		Intelligent positive-negative pulsed charge		Intelligent positive-negative pulsed charge	
	Charging Process	Precharge\Charge\Floating Charge\Full		Precharge\Charge\Floating Charge\Full		Precharge\Charge\Floating Charge\Full		Precharge\Charge\Floating Charge\Full	
	Charging Current	Max20A		Max20A		Max20A		Max20A	
	Charging Voltage	14.5V-16V	29V-32V	14.5V-16V	29V-32V	14.5V-16V	29V-32V	14.5V-16V	29V-32V
	Input Parameter of the Product								
Inverter switch commercial power time	≤ 10ms(Your PC needn' t restart in use of this product)								
Commercial power switch inversion time	≤ 10ms(Your PC needn' t restart in use of this product)								
Required for Inverter switch commercial power	Must matches AC normal operating voltage								
Required for Commercial power switch inversion	No commercial power、AC low voltage protection、AC high voltage protection								
Green LED Operating Indication	Green Light(Operating)								
Red LED Operating Indication	Red Light(Charging)								